

2009 Polaris Ranger XP

REAR Lift Kit Instructions.

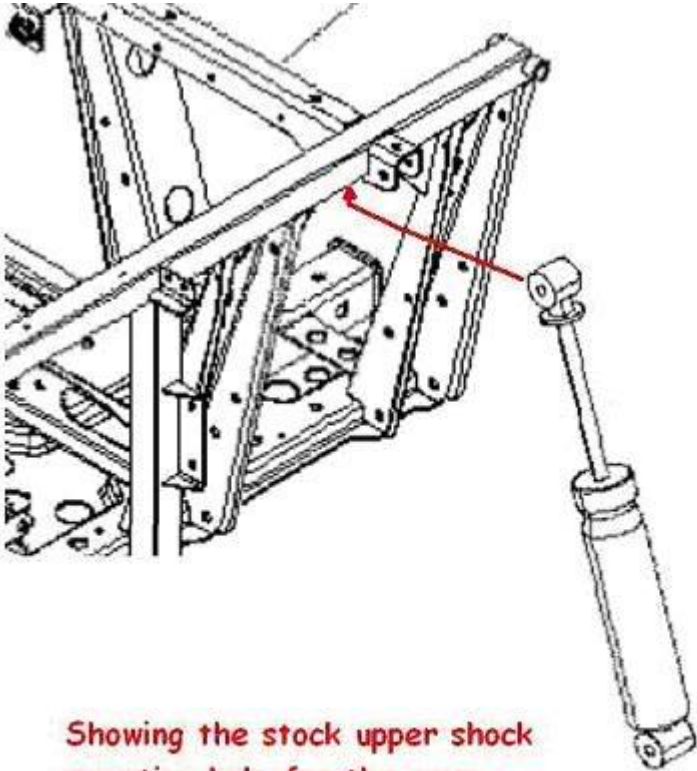

Showing the stock upper shock mounting hole for the rear

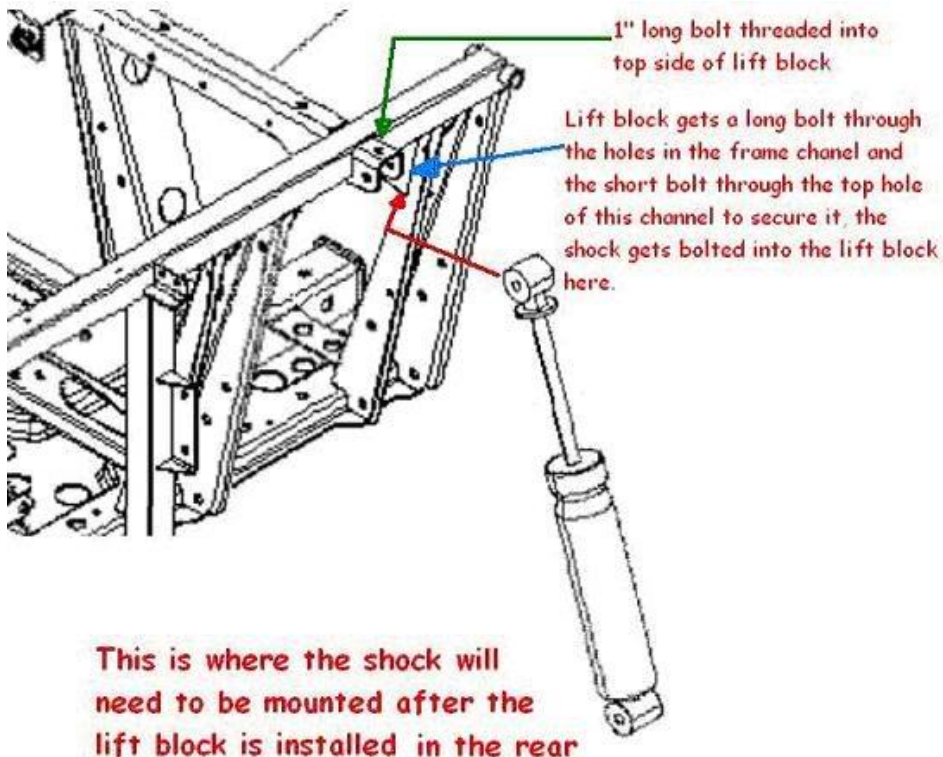

This is where the shock will need to be mounted after the lift block is installed in the rear

Factory shock position, rear left side,



Lift Block installed on rear left side,





Shock mounted in lift block, rear left side,



Front Instructions

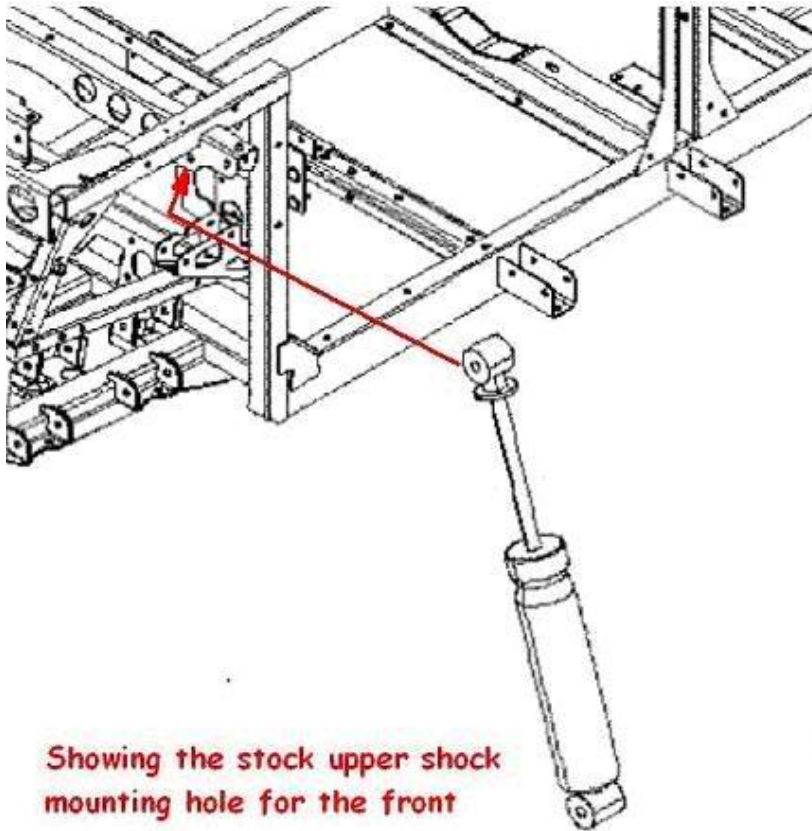

Showing the stock upper shock mounting hole for the front

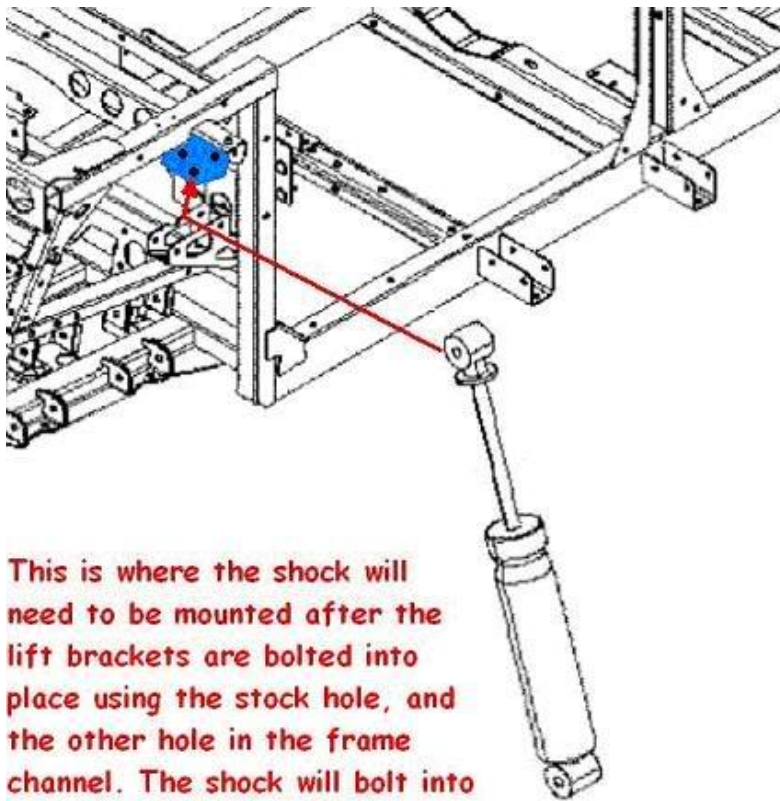

This is where the shock will need to be mounted after the lift brackets are bolted into place using the stock hole, and the other hole in the frame channel. The shock will bolt into location in the brackets.

Factory shock position, Front left side,



Notice the position of 2 aluminum bushings and 1 lift bracket



And now both lift brackets, and the shock mounted into the new position in the center hole location of the lift brackets

